

**DUAL PROCESS**  
**DTEX**  
ODORANT DETECTION SYSTEM





# **DTEX DX1000G/L INSTRUCTION & OPERATING MANUAL**

Version: 03282003



# DX1000G/L TABLE OF CONTENTS

DX1000G/L Table of Contents .....	I
<b>Section 1: First Things To Know .....</b>	<b>1</b>
How to Use this Manual .....	1
Typographic Conventions .....	1
Getting Help .....	1
Operation Specifications .....	2
Introduction .....	2
Theory of Operation .....	3
<b>Section 2: System Installation .....</b>	<b>5</b>
Standard System Components .....	5
System Flow Schematic .....	6
Standard System Connections.....	7
<b>Section 3: System Control &amp; Electronics .....</b>	<b>9</b>
Display and Keypad .....	9
Special Keys .....	10
<b>Section 4: Preparing Your DTEX for a Test .....</b>	<b>13</b>
System Configuration .....	13
<b>Section 5: Programming For Odor Concentration Operation .....</b>	<b>15</b>
Conducting An Odor Concentration Test .....	15
<b>Section 6: Programming For Odor Intensity Operation .....</b>	<b>23</b>
Conducting An Odor Intensity Test .....	23
<b>Section 7: System Maintenance .....</b>	<b>31</b>
Recommended Maintenance .....	31
Recharging the Battery .....	31
Cleaning .....	31
Venting and Purging .....	31
Recommended Spare Parts .....	31
Annual Re-Calibration/Inspection .....	32
Annual Re-Calibration/Inspection Information Sheet .....	33



# SECTION 1: FIRST THINGS TO KNOW ABOUT THE DTEX

## How to Use this Manual

The DTEX 1000G/L Operations Manual is a step-by-step guide containing the procedures needed to work with the DTEX 1000G/L System.

The DTEX Instruments implement the most advanced technology available in the industry. It is recommended that the technicians working with the DTEX Instruments study the manual prior to initiating work on the system for the first time.

## Typographic Conventions

To aid in readability, this manual uses several typographic conventions. References to illustrations, photographs, and other related content will appear in *italicized text* along with the location of where to find the item in the manual. Digital versions of the manual, available in Adobe Acrobat™ PDF format, will be highlighted further in *blue italic text* indicating the copy retains a hyperlink to the referenced item.

Measurement units are listed in italic parenthesis text following their US standard equivalent. As an example, for defining a distance, 15' (*4.5 meters*), is how the text will appear throughout the manual.

Items that require action, for example the pressing of a key for programming the controller, will feature the action item in sentence case **Bold Text** followed in normal text by the item such as, the **Up Arrow** key or **Main Power** switch.

## Getting Help

This manual provides solutions to typical questions about the DTEX 1000G/L system. If the answer can not be found within this manual, contact YZ Systems at:

T: 1.936.788.5593  
T: 1.800.653.9435  
F: 1.936.788.5720  
Em: Service@yzhq.com

When calling, have this manual close at hand. Whether calling or writing, please include in your communicate the following information:

- The serial number, and firmware version number of the DTEX Instrument and the version number of this manual. The serial number, and firmware version number are available on the DTEX display, when powering the instrument up. *Refer to Information in Section 3 on page 10.* The serial number is also located on the model number plate located between the hinges on the back of the enclosure. The version number of this manual is located at the bottom of each page.
- A description of the problem and, if applicable the actions of the technical personnel when the problem occurred.

# SECTION 1: FIRST THINGS TO KNOW ABOUT THE DTEX

## Operation Specifications

Maximum Operating Pressure:	5 psig (0.345 Bar (g))
Minimum Operating Pressure:	5" water column
Operating Temp Range:	*0 to 140 degrees F. (17°C to 60°C)
Power Supply:	12VDC Internal Rechargeable Battery

---

### **CAUTION:**

*The DTEX system is designed to evaluate odor intensity in gas streams. Because of the potentially hazardous nature of conditions and elements involved in conducting tests, users are reminded to use extreme caution while operating the DTEX system. The system operated improperly or past due calibration could create a dangerous situation to both persons or property as well as produce inaccurate test results. \*Refer to D6273-98 ASTM Standard Test Methods for Gas Odor Intensity for guidance regarding precautions, hazards and procedures.*

---

## Introduction

Congratulations on your purchase of the DTEX DX 1000G/L odorant detection system. You've made a wise investment for your company.

DTEX is a small, handheld instrument, which assists the user in determining the odorant intensity of Natural Gas/LPG with menu-driven, step-by-step instructions. After connecting to the sample point, sniff test completion times typically run 2 to 3 minutes. The DTEX system displays the actual air/gas percentage, present in the device, thus eliminating the need for flow tubes and cross-reference charts. With an on-board database of 50 test locations, DTEX can record multiple tests for each test location, including **Threshold Detection Level (TDL)** and **Readily Detectable Level (RDL)** readings and test notes, such as odor intensity ratings, weather conditions, etc. Then, DTEX goes one-step further by storing up to 75 complete test results electronically. Back at the office the test results can be individually reviewed or downloaded into a PC. It's that simple.

Other important features of the DTEX system are:

- Inherently safe for hazardous locations Class 1, Division I, Groups C&D
- Low power circuitry
- Rechargeable battery
- Rugged enclosure
- Completely portable
- Ergonomically designed for compatible operator interface
- Odorant level detection reports are no longer manually written

This Manual Covers both versions, Natural Gas and LPG. Applies to DTEX 1000 G and L.



# SECTION 1: FIRST THINGS TO KNOW ABOUT THE DTEX

## Theory of Operation

Two procedures for determining odor intensity are outlined in *ASTM D 6273*, the **Odorant Concentration Method**, and the **Odor Intensity Method**. Either, or both procedures may be utilized with this DTEX instrument. The tests can be conducted at any desired point in a gas transmission or distribution system, as long as proper test pressure is assured. The DTEX system can accept inlet pressures from 5" water column, up to 5 psi. Any system pressure above this will require a reduction regulator prior to the inlet of the DTEX system. The gas stream to be tested enters the DTEX system through the gas inlet connection. It then passes through a low pressure regulator, and on to the gas flow adjustment valve. This valve is adjusted by the operator during a test to obtain either **Threshold Detection Level (TDL)**, **Readily Detectable Level (RDL)**, or **% of Desired Gas Concentration in Air**. The gas then passes through the electronic mass flow sensor, and on to the mixing chamber where it is mixed with intake air. A micro processor-based control algorithm is employed to ensure constant fan speed at given altitude and temperature. The air/gas mixture is then delivered to the sniff chamber where it is evaluated by the operator.

---

### **CAUTION:**

*\*Prolonged use of sense of smell may result in olfactory fatigue; therefore take all necessary steps to assure that exposure to odorized gas is limited.*

---

When the desired odorant test level is detected, the operator simply pushes the record test level button once to record the test data into memory. Additional notes may be added to the test data, as required. Actual test readings are visible to the operator at the main display after the test has concluded. Up to 75 separate tests can be stored in the system. All data can be downloaded to a host PC and periodically appended and permanently stored creating a paperless audit trail of odorant level detection tests. These tests can later be analyzed for trends or other statistical information.

\* *ASTM D 6273*



## SECTION 2: SYSTEM INSTALLATION

### Standard System Components

The primary components of the DTEX DX 1000G/L system are illustrated here:

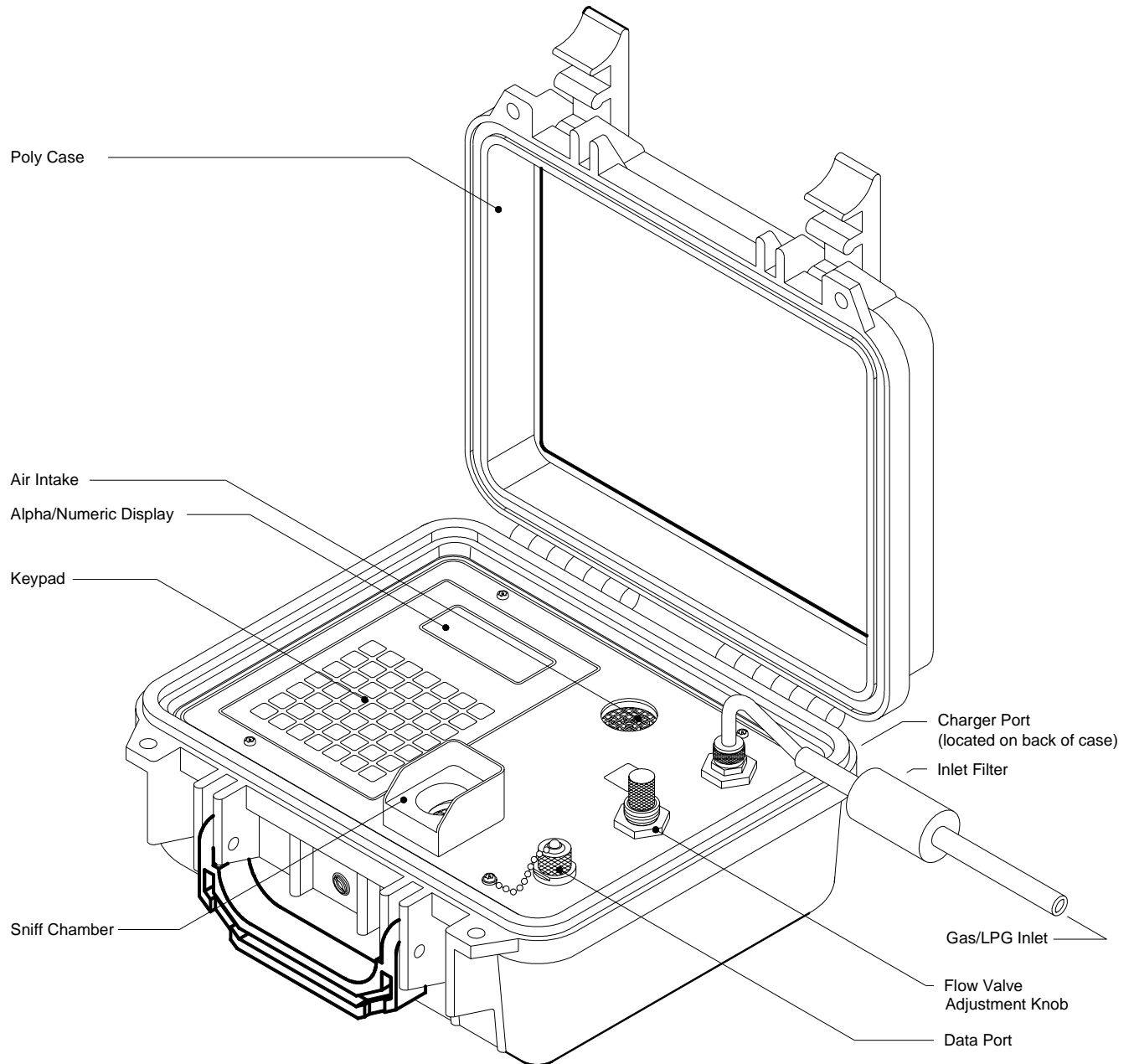

# SECTION 2: SYSTEM INSTALLATION

## System Flow Schematic

Illustrated below are the major internal components and a flow diagram of the DTEX system.

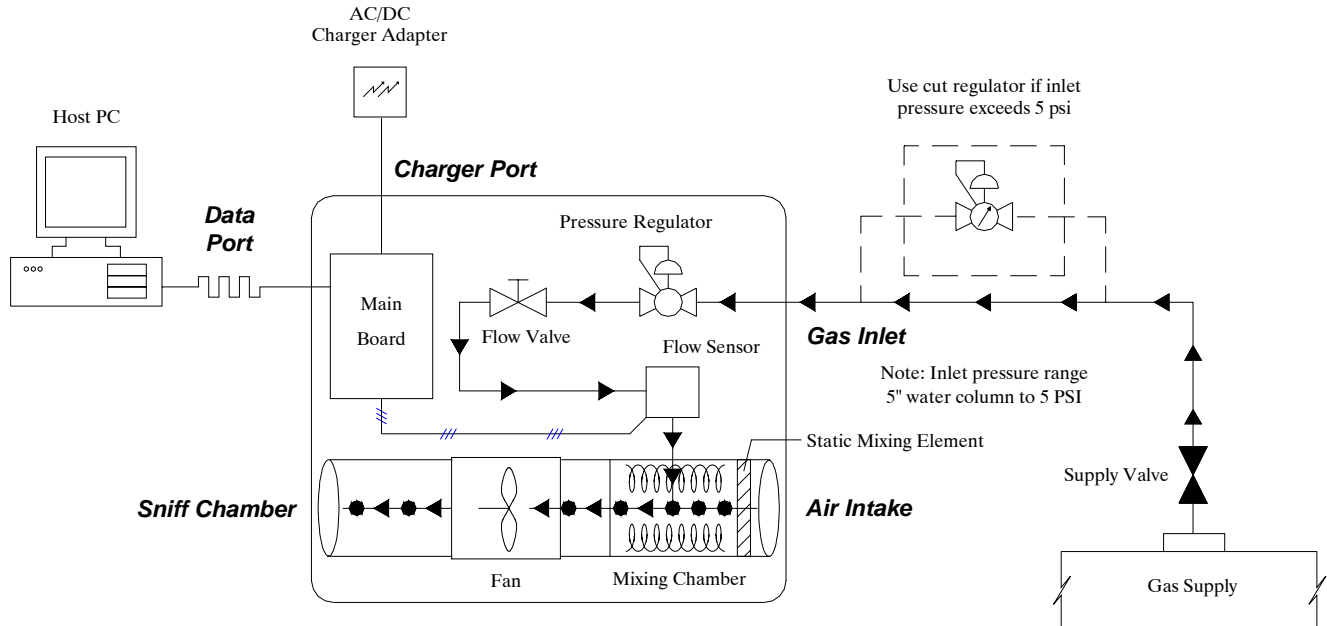

### LEGEND

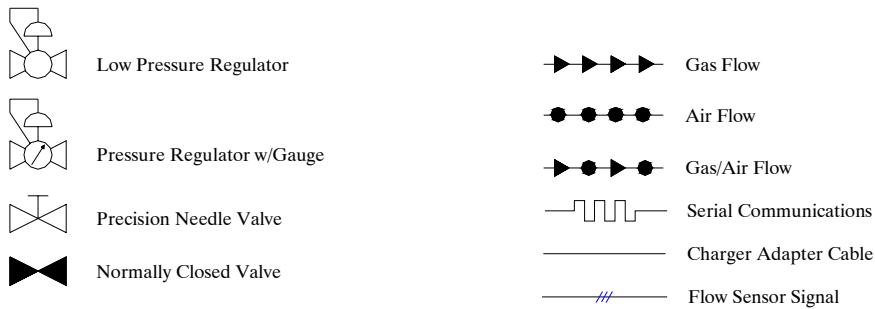

# SECTION 2: SYSTEM INSTALLATION

## Standard System Connections

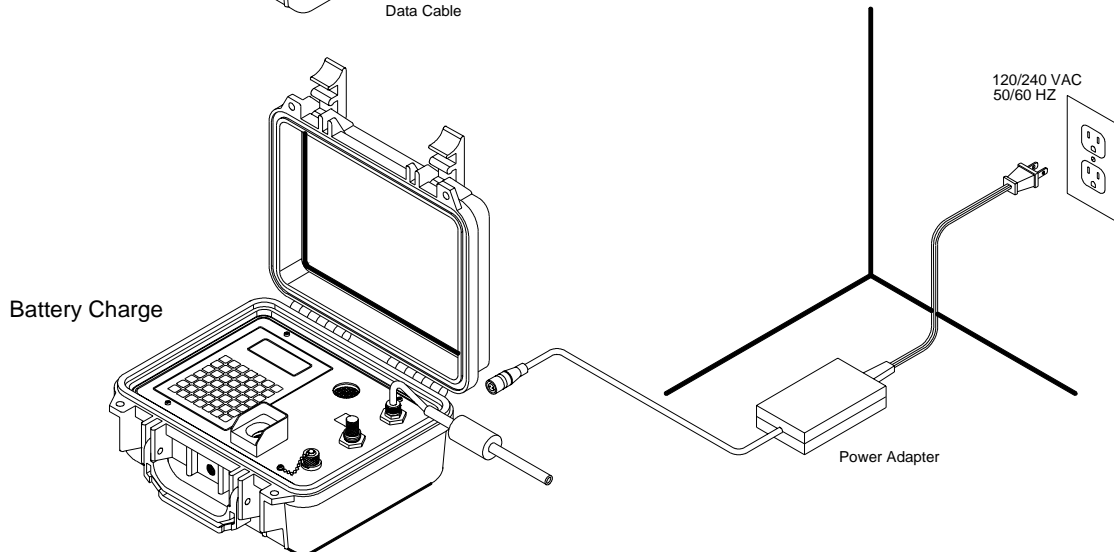
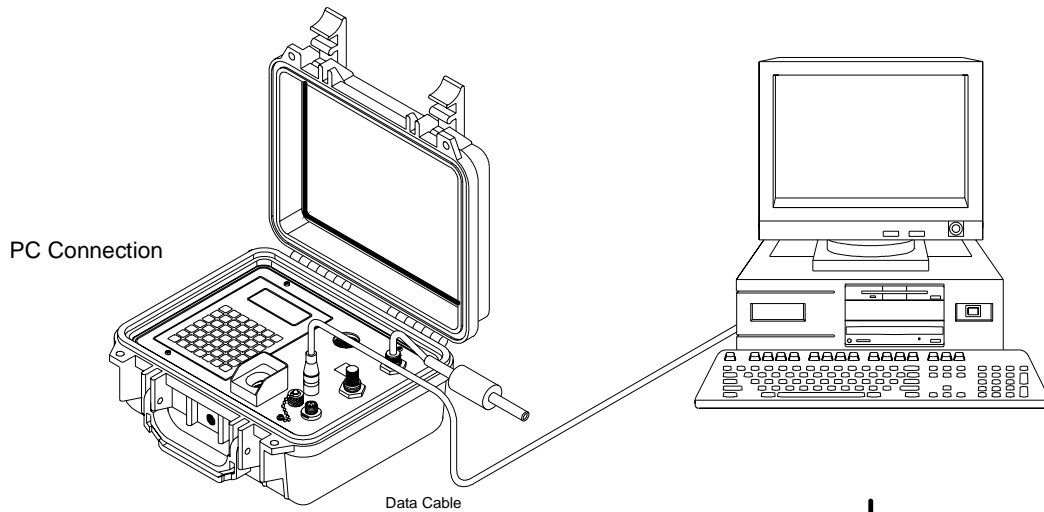
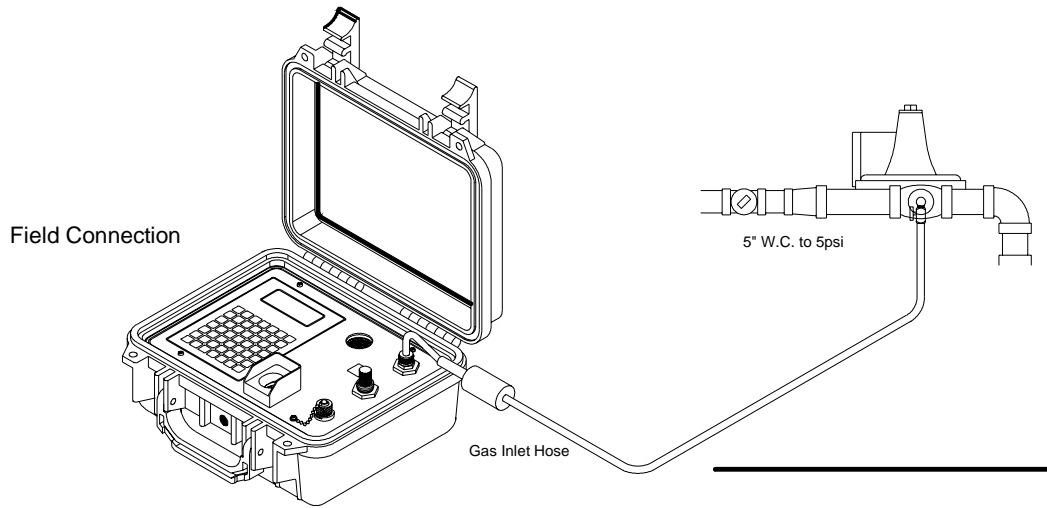



# SECTION 3: SYSTEM CONTROL & ELECTRONICS

## System Electronics

Display and Keypad:

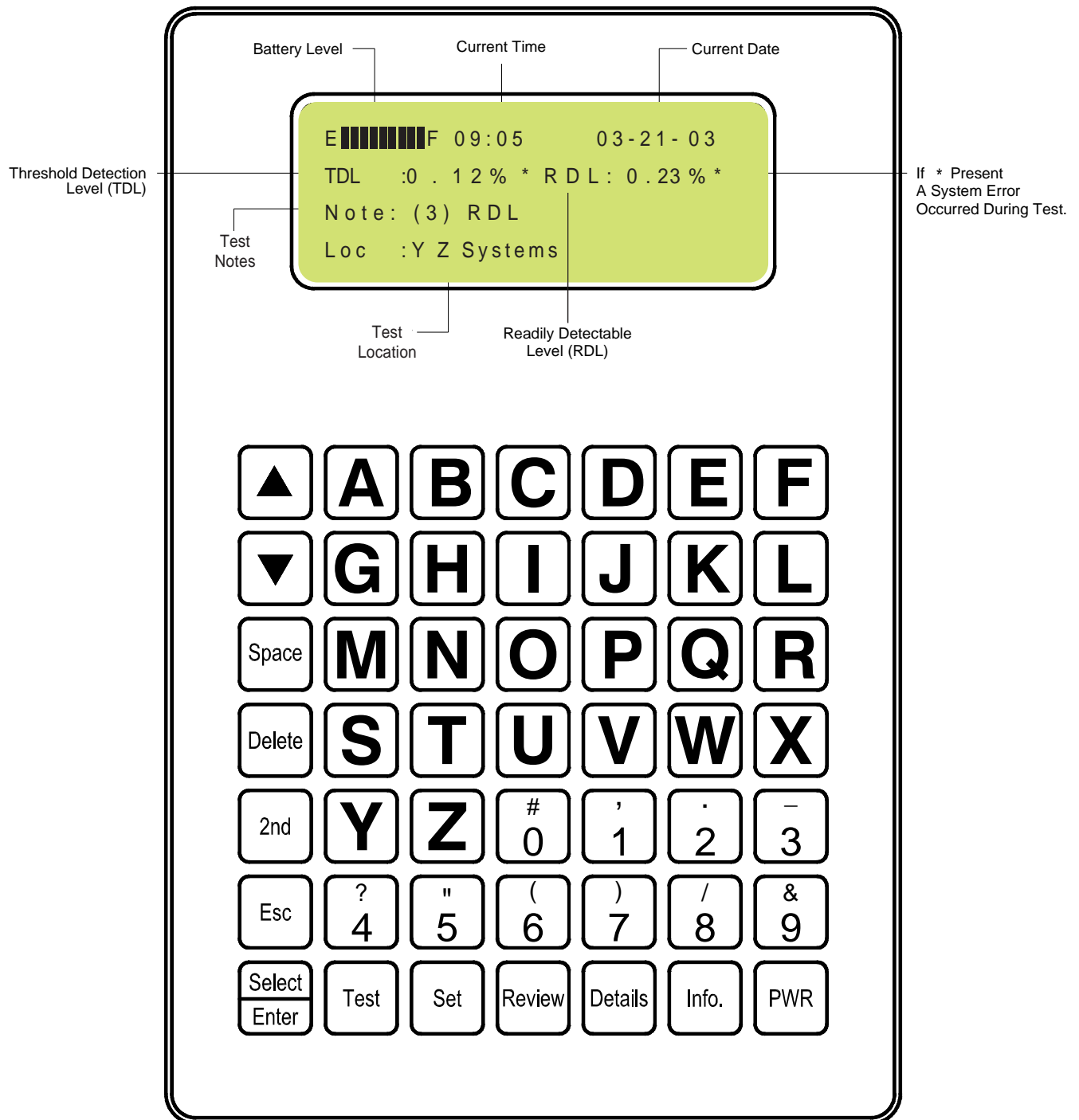

# SECTION 3: SYSTEM CONTROL & ELECTRONICS

## System Electronics

### Special Keys:

Below is a quick reference for all DTEX system special keys.

Key	Function
▼/▲	Used to move on-screen pointer up/down or to scroll the screen up/down.
Space	Used to insert a blank character.
Delete	Used to delete a character of text
2nd	Used to access the symbols depicted on the number keys.
ESC	Use to back up to a previous menu or abort an operation.
Select Enter	Used to select an item with the on screen pointer or to enter text.
Test	Used to start test, set locations, and toggle between Odor Concentration and Odor Intensity test modes
Set	Used to set time of day.
Review	Used to review basic test data.
Details	Used to review detailed test data
Info.	Used to view unit information
PWR	Turns DTEX unit On/Off

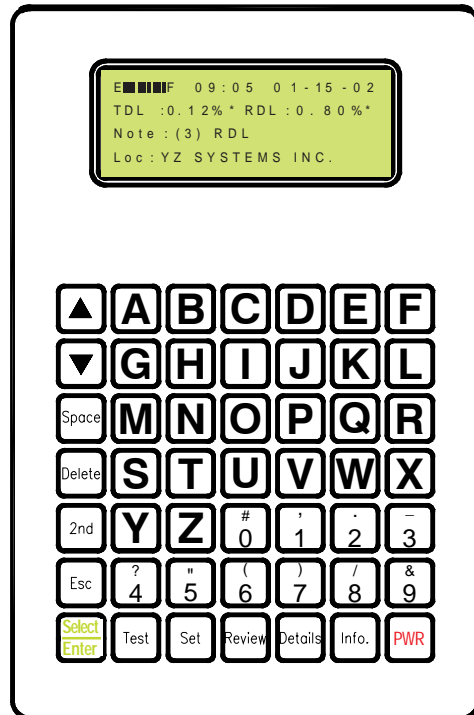

The DTEX system includes several special information keys. These allow the user to access system information and basic or detailed test results. Results of any test currently stored in the system may be accessed and reviewed at anytime. To access, power on the system and sign on. The following keys are accessible from the main menu screen. Press ESC at any time to return to main menu.

### INFORMATION:

The information key allows access to DTEX system information. It will be necessary to furnish this information in the event of a technical service or support inquiry to the factory, or for customer records. Use the arrow keys to view all available information.

The following information is displayed:

- Model No.                      Version No.
- Serial No.
- Calibrated (last factory calibration)
- Next Scheduled (factory calibration)
- Last Error (system malfunction error message)

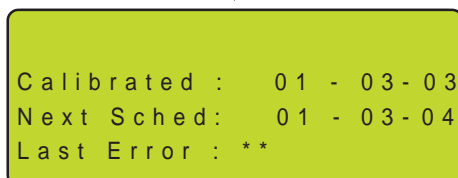
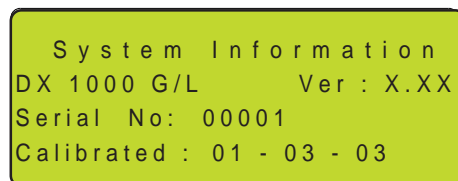



# SECTION 3: SYSTEM CONTROL & ELECTRONICS

## System Electronics

Special Keys:

### REVIEW:

The review key allows for user to review basic information relative to any test currently stored in the system. Use the **arrow keys** to scroll to the desired test to be reviewed.

The following information will be displayed:

Test No.                      Time of Test    Date of Test  
TDL:0.00%    RDL:0.00%  
Note: (3) RDL  
Loc: YZ Systems

### DETAILS:

The details key allows for review of all information relative to the test previously selected by the review key. Use the arrow keys to view all available information.

The following information will be displayed:

#### Test Details

Test No.                      Time of Test    Date of Test  
TDL:0.00%    RDL:0.00%  
Test Notes:  
Location Name  
Location Address  
User Name  
Test Duration (sec.)  
Altitude (feet)  
Temperature (°C)

### SET:

The set key allows the operator to adjust the time of day. Follow on-screen instructions.

### TEST:

- Press the test key to begin a **Test**.
- Press the test key to enter new test locations and addresses. (Follow on-screen instructions)
- Press the test key at the beginning of a test to toggle between Odor Concentration, or Odor Intensity test methods.

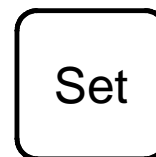
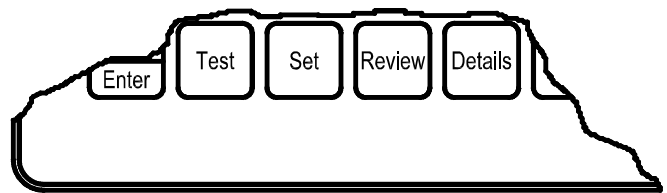



# **SECTION 4: PREPARING YOUR DTEX FOR A TEST**

## **System Configuration**

The DTEX system can be up loaded with all required test location and user data prior to conducting tests via host PC and DTEX Reporter Software. This facilitates more efficient and simpler use of the DTEX system by requiring less user and location data input each time a test is conducted.

The following items can be uploaded into the system using reporter software:

- User names
- User personal identification numbers (PIN)
- Test locations
- Test location cities
- Test location states/provinces
- Test location zip codes
- Altitudes

For instructions on configuring and uploading the DTEX system and other features of Reporter Software, please refer to the Reporter user's manual.

Should on-site initial configuration, changes, or new additions to the DTEX system need to be made, please [refer to Sections 5 or 6: Programming Operations - Detailed.](#)

## **SECTION 4: PREPARING YOUR DTEX FOR A TEST**

### **Things to Remember**

#### **WARNING**

The DTEX system is designed to evaluate odor intensity in gas streams. Because of the potentially hazardous nature of conditions and elements involved in conducting tests, users are reminded to use extreme caution while operating the DTEX system. The system operated improperly or past due calibration could create a dangerous situation to both persons or property as well as produce inaccurate test results. Refer to D6273-98 ASTM Standard Test Methods for Gas Odor Intensity for guidance regarding precautions, hazards and procedures.

Before conducting tests at a site, investigate and eliminate any possible ignition source in the immediate area.

Should the user detect or suspect a leak prior to or during a test, immediately shut off the source isolation valve and seek the cause.

Avoid conducting tests in closed or confined spaces.

Avoid conducting tests in windy conditions.

Operators of the DTEX system should possess an "average" sense of smell. This will provide more consistent results from test to test. Consideration should be given to circumstances which could affect sense of smell such as colds, medication, smoking, etc.

Be aware that user sense of smell can be diminished due to prolonged exposure to odors. Odor intensity readings should be based on the first few sniffs. Occasionally, the user should pause between sniffs and breath fresh air to rejuvenate sense of smell, then resume the test.

Maximum inlet pressure to the DTEX system is 5 psi. If test source pressure exceeds 5 psi, install a pressure reduction regulator prior to the gas inlet.

**Do not overtighten the flow valve --- DAMAGE WILL RESULT! Lightly bottom the valve knob after use.**

# SECTION 5: PROGRAMMING FOR ODOR CONCENTRATION OPERATION

## Conducting An Odor Concentration Test:

**WARNING:** System inlet pressure not to exceed 5 psi.

**Step 1:** Connect the gas inlet hose to the test source connection and open the source isolation valve.

**Step 2:** Power up the system by pressing the **PWR** button on the keypad.

The fan will begin to run automatically as part of a system hardware check.

The screen will display the following:

**Checking Hardware:** automatic system hardware check prior to a test.

**Step 3:** Press **Enter** to skip the purge cycle if desired\* (to review data, repeat a test, etc.)

\*Press **P** to purge the unit before a test. Open the flow valve fully until you smell gas then close valve and press **Enter** to continue.

### **CAUTION:**

*This is essential if this is the initial use of the system at this test source connection. The gas inlet hose and internal regulator **must** be filled with gas prior to running a test for accurate test results.*

The screen will scroll automatically and display the following information.

### **DTEX Model/Version/Serial No**

Please refer to this information for your company's records and for any technical service inquiries to YZ Systems.

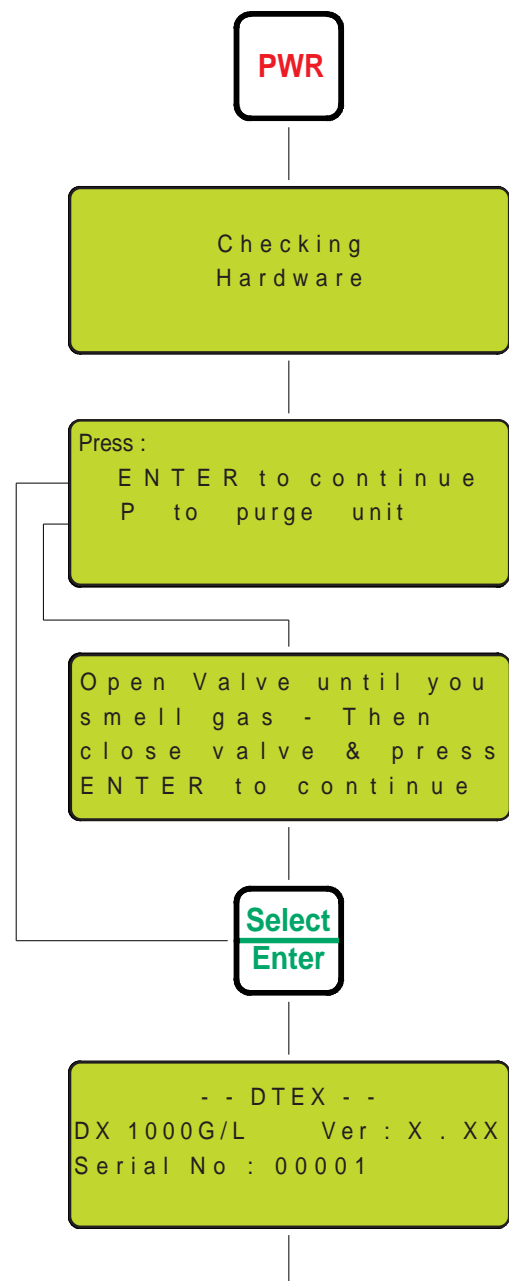
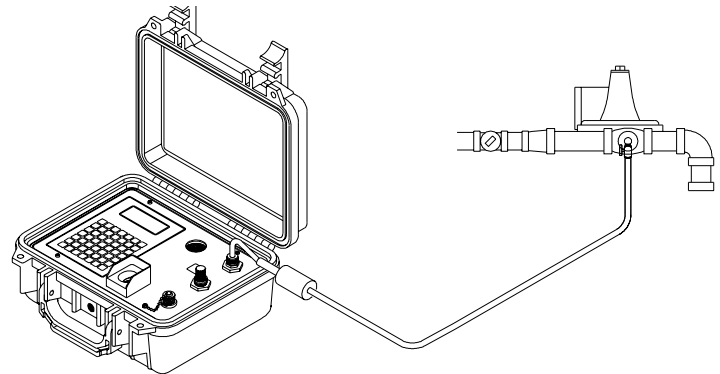

# SECTION 5: PROGRAMMING FOR ODOR CONCENTRATION OPERATION

## Conducting An Odor Concentration Test: (cont.)

### Calibration:

Date system was last factory calibrated and date system is due for factory re-calibration.

**Step 4:** Press **Enter** to sign on. Press the **Enter** key on the keypad to begin data configuration for a test.

**Step 5:** Set User by using the **arrow keys**, select the user name and press **Enter**. Proceed to Step 6.

*If the correct name is not present, select **Add User** and press **Enter**.*

### ENTER NEW USER

Type in the new user name and press **Enter**.

### ENTER USER PIN

Select and type in a 2 digit personal identification number and press **Enter**.

### RE-ENTER USER PIN

Type in the above selected number and press **Enter** for verification.

### SET USER

The new user name should now be displayed. Use the **arrow keys** to select the user and press **Enter**.

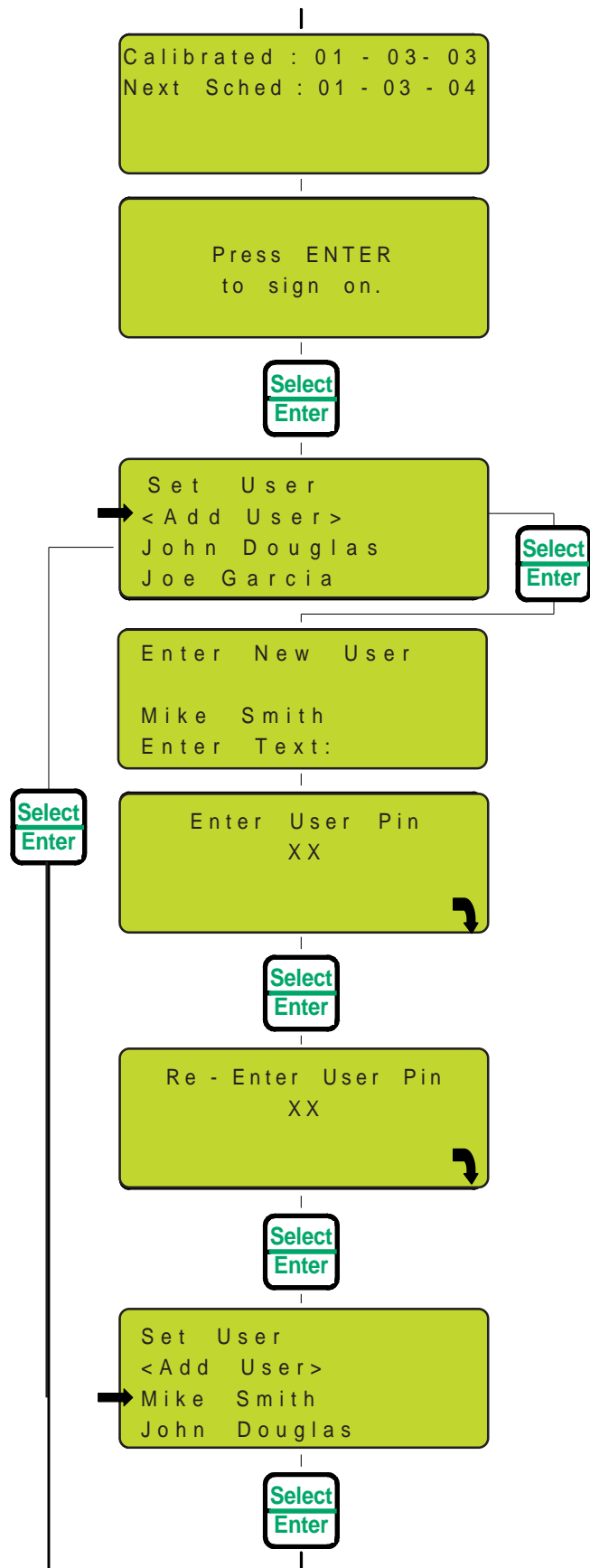

# SECTION 5: PROGRAMMING FOR ODOR CONCENTRATION OPERATION

## Conducting An Odor Concentration Test: (cont.)

**Step 6:** Enter User PIN by typing in user 2 digit personal identification number and press **Enter**.

The main display will now be present.

**Step 7:** Press the **Test** button on the keypad.

**Step 8:** Set location using the **arrow keys**, select the Test Location and press **Enter**. Proceed to Step 9.

*If the correct location is not present select **New Item** and press **Enter**.*

### NEW LOCATION

Type in the new location and press **Enter**.

### NEW ADDRESS

Type in the address of the new location and press **Enter**.

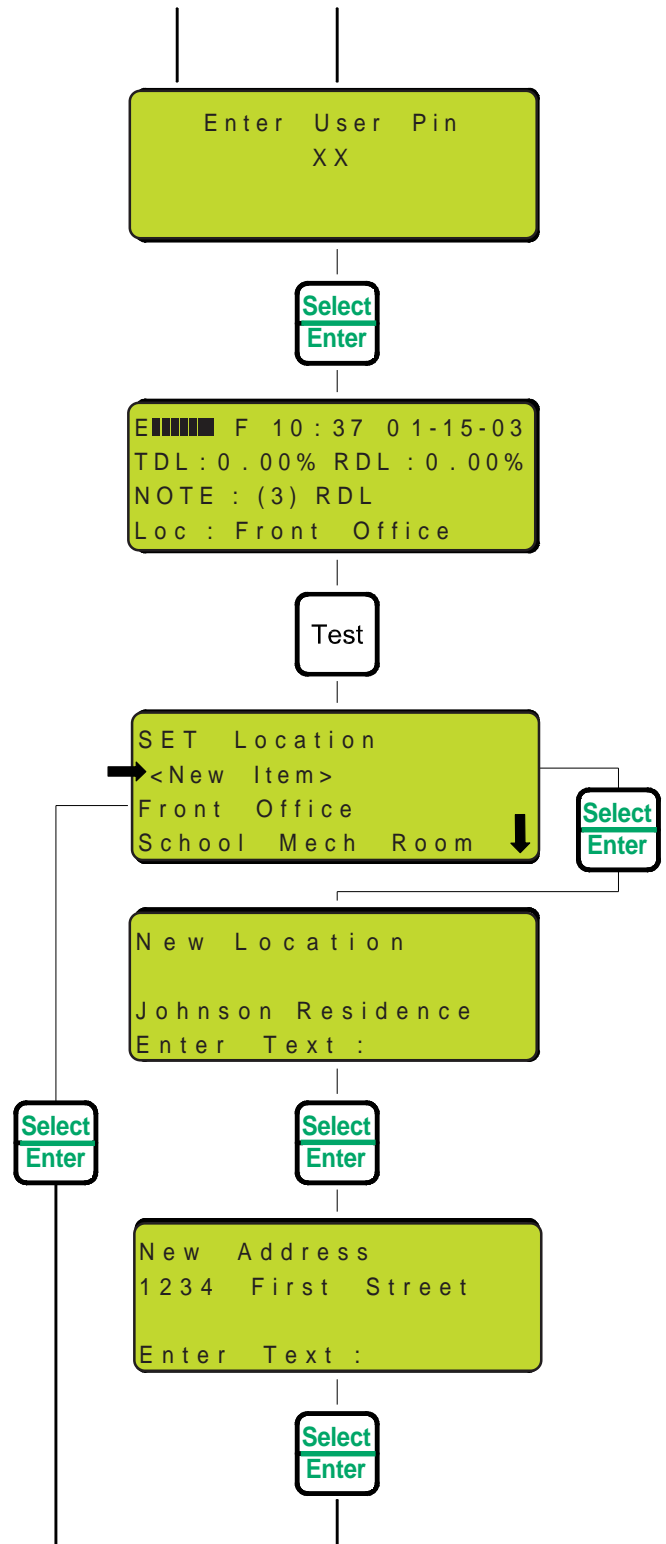

# SECTION 5: PROGRAMMING FOR ODOR CONCENTRATION OPERATION

## Conducting An Odor Concentration Test: (cont.)

Set City using the **arrow keys**, select the city and press **Enter**.

*If the correct city is not listed, select **New Item** and press **Enter**.*

New City: type in the name of the **New City** and press **Enter**.

Set State/Province using the **arrow keys**, select the state and press **Enter**.

*If the correct State/Province is not listed select **New Item** and press **Enter**.*

New State: type in the name of the new State/Province and press **Enter**.

Set Zip/Postal Code using the **arrow keys**, select the correct zip code and press **Enter**.

*If the correct Zip Code in not listed select **New Item** and press **Enter**.*

New Zip/Postal Code: type in the new zip/postal code and press **Enter**.

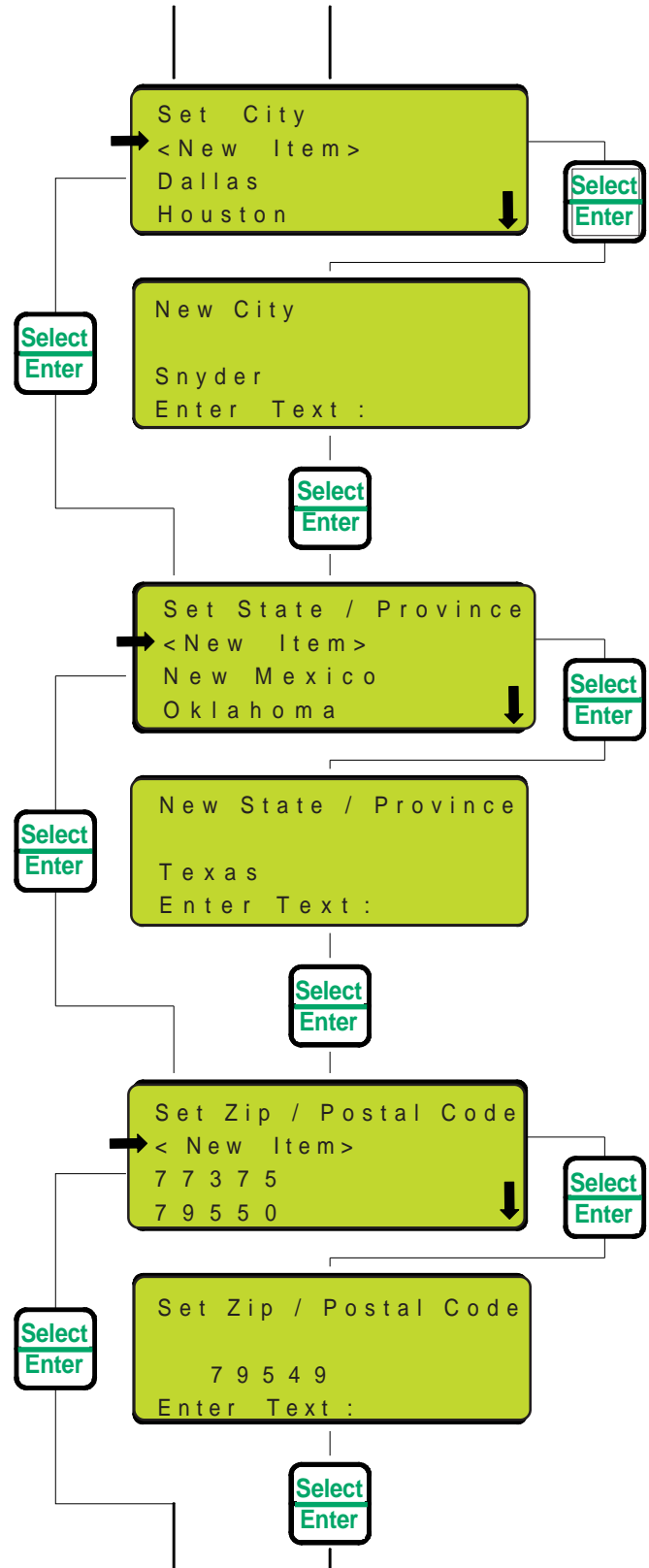



# SECTION 5: PROGRAMMING FOR ODOR CONCENTRATION OPERATION

## Conducting An Odor Concentration Test: (cont.)

**Step 9:** Set the altitude using the **arrow keys** and press **Enter**. (Set to nearest 500 feet.)

**Step 10:** Verify Data: verify that all data entered for test location is correct by using arrow keys to scroll through data. Press **Enter** to continue.

**Step 11:** Is Data Correct? If correct, select **Yes** and press **Enter** and proceed to Step 12. If data is incorrect select **No** and press **Enter**. Re-enter information as required.

*The configuring hardware display will be present and the unit will begin to run to configure hardware for a test.*

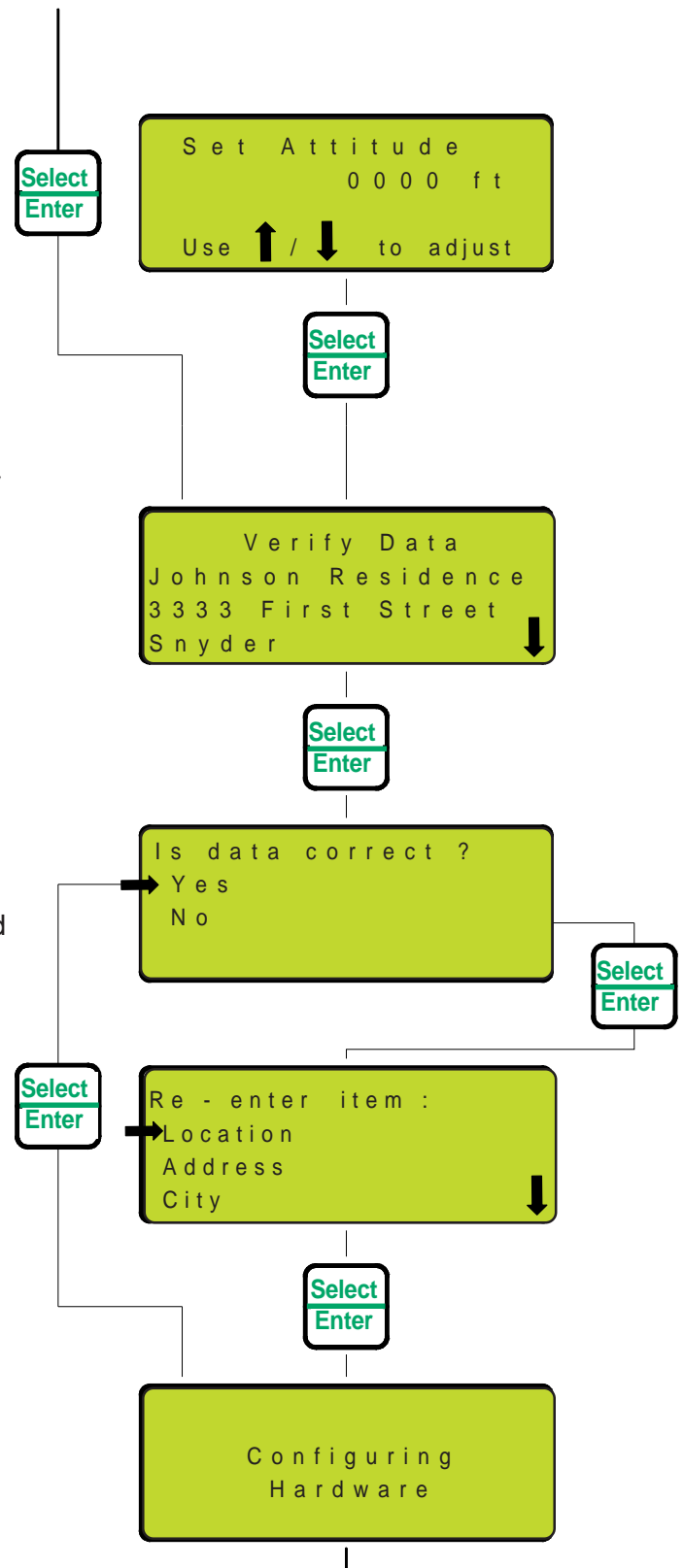

# SECTION 5: PROGRAMMING FOR ODOR CONCENTRATION OPERATION

## Conducting An Odor Concentration Test: (cont.)

**Step 12: Threshold Detection Level (TDL) Test:** position nose within 3/4 inch of the sniff chamber and with valve closed sniff exhaust. If an uncharacteristic odor is detected allow the instrument to operate for an additional 2 minutes. If uncharacteristic odor persists, perform an exhaust background evaluation test as specified in Section 7 - System Maintenance. Slowly open the flow valve and sniff exhaust. Continue to open the valve and sniff, getting breaths of fresh air between sniffs. Continue the procedure until the first hint of a new odor is detected. This is the **threshold detection level**. Threshold, as used here, is the minimum concentration of a gas in air when one detects a new or different odor (above the background/characteristic odor of instrument). Remove nose from sniff chamber.

**Step 13:** Press the **Record Test Level (RTL)** key recording the **threshold detection level**\*

**Step 14: Readily Detectable Level (RDL) Gas Odor Test:** again position nose within 3/4 inch of the sniff chamber. Continue opening flow valve until readily detectable odor of gas is attained. RDL determination should be where Natural Gas / LPG odor can be positively identified as Natural Gas / LPG gas. Remove nose from sniff chamber.

**Step 15:** Press the **Record Test Level (RTL)** key.

*\*refer ASTM D6273-98 definitions*

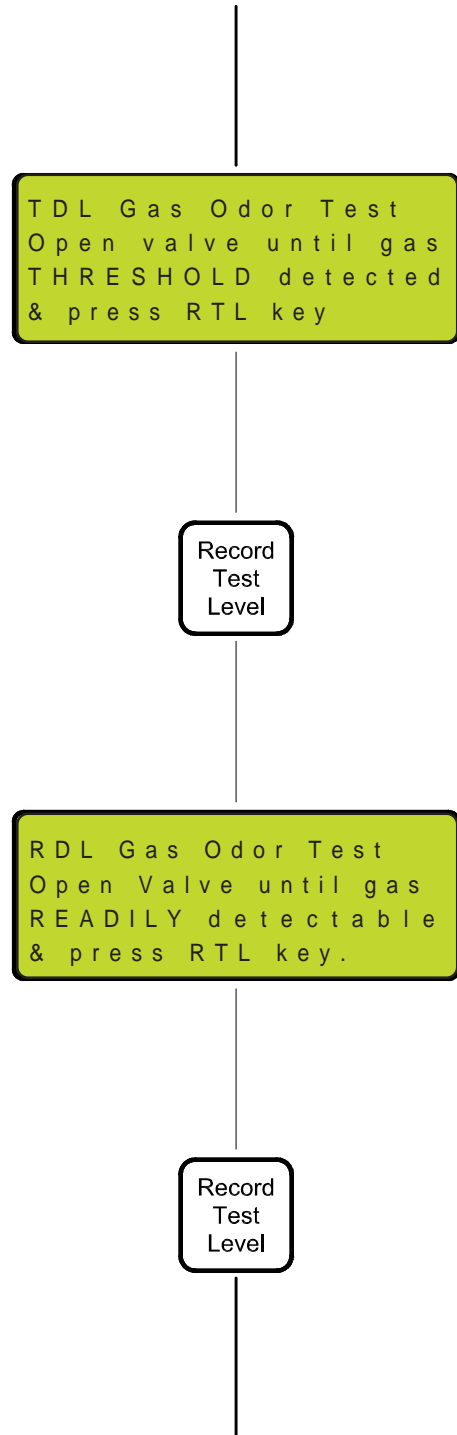

# SECTION 5: PROGRAMMING FOR ODOR CONCENTRATION OPERATION

## Conducting An Odor Concentration Test: (cont.)

**Step 16:** Test Complete: Close valve and press **Enter**.

**Step 17:** Add Any Notes: *type in any supplemental data to be recorded with this test and press **Enter**.*

The main display will be present and test results are revealed to the operator.

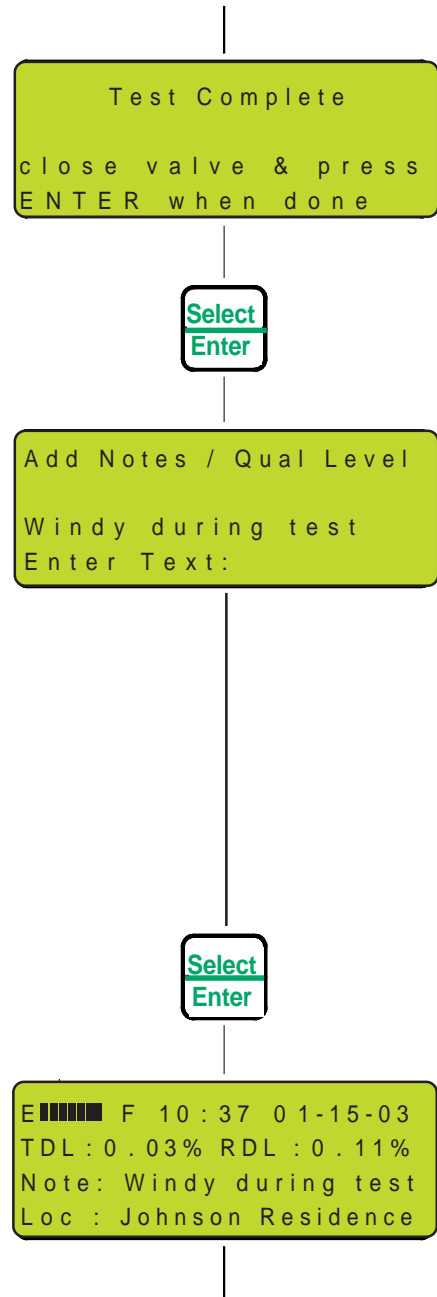

# SECTION 5: PROGRAMMING FOR ODOR CONCENTRATION OPERATION

## Conducting An Odor Concentration Test: (cont.)

**Step 18:** press the **PWR** key.

The following will be displayed:

Press: **PWR** to shut down  
**V** to vent unit  
**ESC** to abort

When finished with a test, the operator has the option to:

**PWR TO SHUT DOWN:** power down the system without venting.

To be used after data review or data entry when no gas source connection has been made.

**V TO VENT UNIT:** vent the system before shut down.

Recommended after each test to prevent undue saturation of inlet hose, system components and residual smell in the unit.

To vent:

1. Close the source isolation valve.
2. Remove the gas inlet hose from the source connection.
3. Press **V** to vent.
4. Open the flow valve fully.
5. Wait until prompted on screen.
6. Close flow valve.
7. Press **PWR** to shut down.

**ESC TO ABORT:** to review or re-run the previous test.

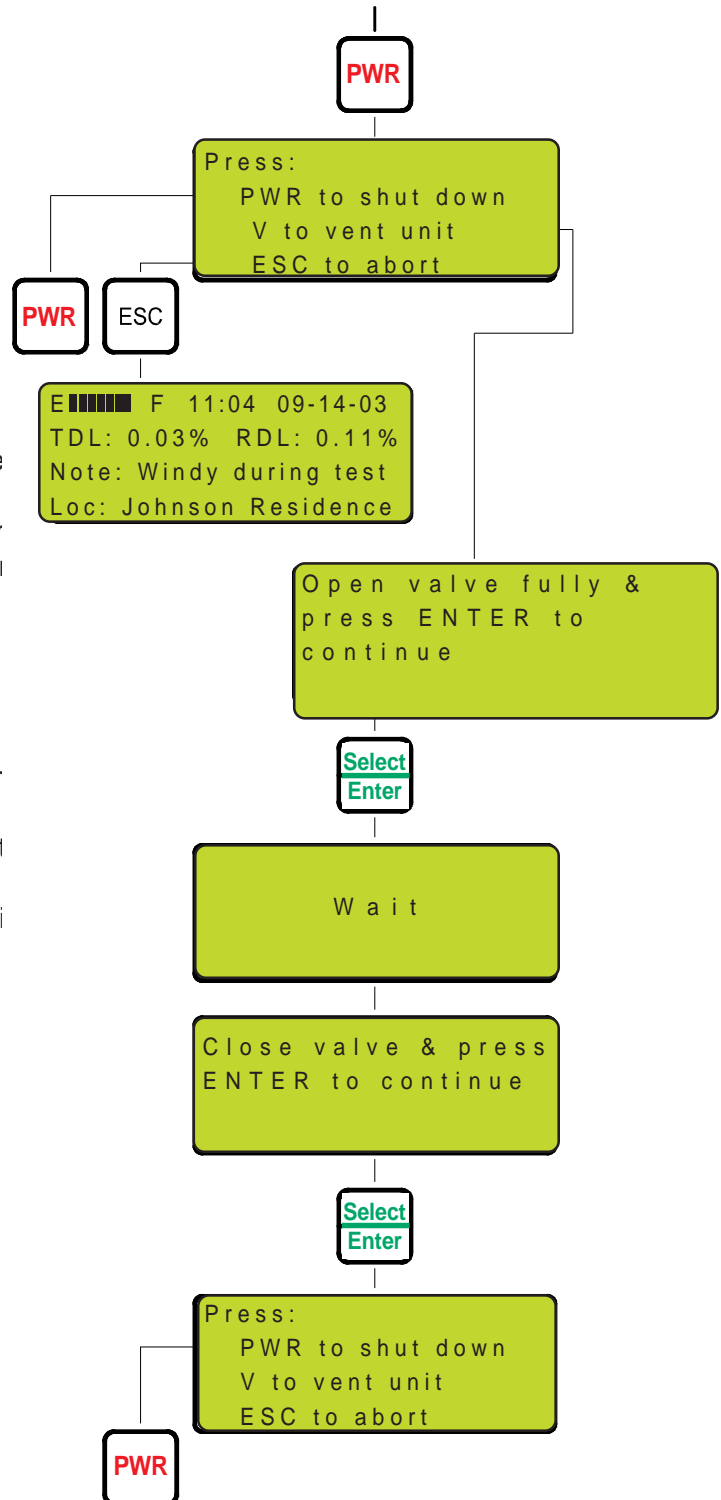

# SECTION 6: PROGRAMMING FOR ODOR INTENSITY OPERATION

## Conducting An Odor Intensity Test:

**WARNING:** System inlet pressure not to exceed 5 psi.

**Step 1:** Connect the gas inlet hose to the test source connection and open the source isolation valve.

**Step 2:** Power up the system by pressing the **PWR** button on the keypad.

The fan will begin to run automatically as part of a system hardware check.

The screen will display the following:

**Checking Hardware:** automatic system hardware check prior to a test.

**Step 3:** Press **Enter** to skip the purge cycle if desired\* (to review data, repeat a test, etc.)

\*Press **P** to purge the unit before a test. Open the flow valve fully until you smell gas then close valve and press **Enter** to continue.

### CAUTION:

*This is essential if this is the initial use of the system at this test source connection. The gas inlet hose and internal regulator **must** be filled with gas prior to running a test for accurate test results.*

The screen will scroll automatically and display the following information.

### DTEX Model/Version/Serial No

Please refer to this information for your company's records and for any technical service inquiries to YZ Systems.

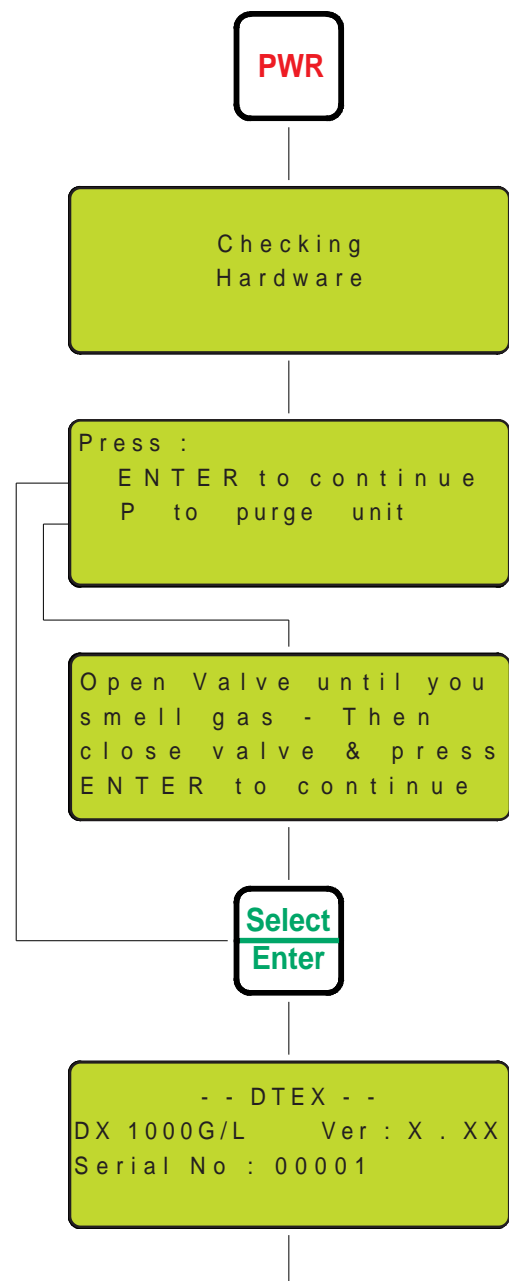
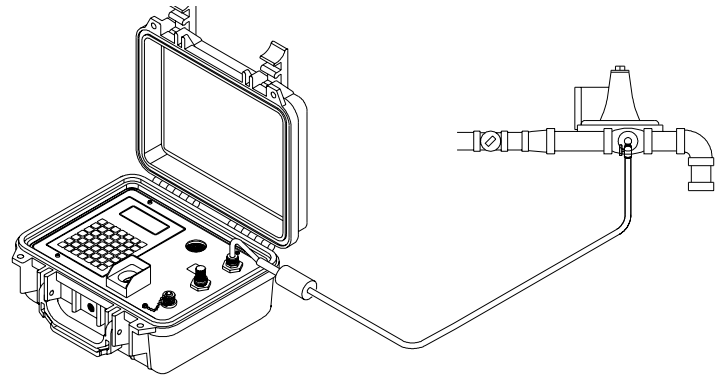

# SECTION 6: PROGRAMMING FOR ODOR INTENSITY OPERATION

## Conducting An Odor Intensity Test: (cont.)

### Calibration:

Date system was last factory calibrated and date system is due for factory re-calibration.

**Step 4:** Press **Enter** to sign on. Press the **Enter** key on the keypad to begin data configuration for a test.

**Step 5:** Set User by using the **arrow keys**, select the user name and press **Enter**. Proceed to Step 6.

*If the correct name is not present, select **Add User** and press **Enter**.*

### ENTER NEW USER

Type in the new user name and press **Enter**.

### ENTER USER PIN

Select and type in a 2 digit personal identification number and press **Enter**.

### RE-ENTER USER PIN

Type in the above selected number and press **Enter** for verification.

### SET USER

The new user name should now be displayed. Use the **arrow keys** to select the user and press **Enter**.

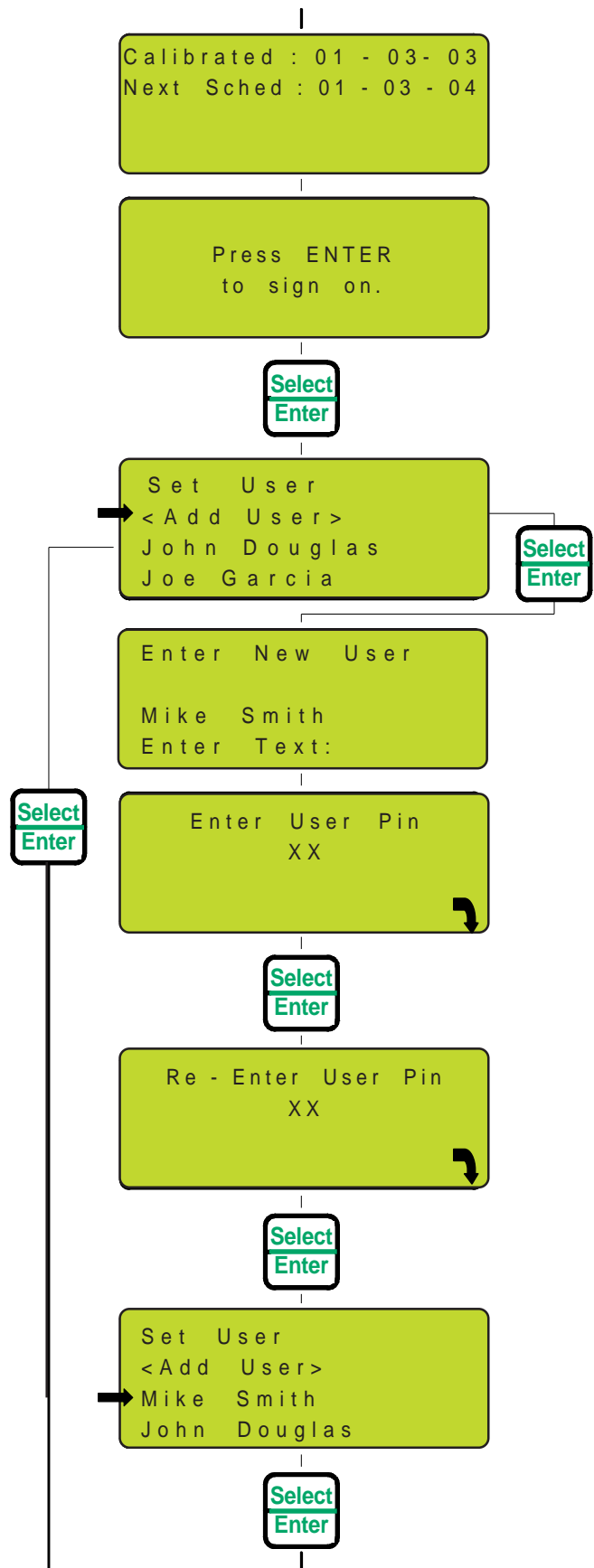

# SECTION 6: PROGRAMMING FOR ODOR INTENSITY OPERATION

## Conducting An Odor Intensity Test: (cont.)

**Step 6:** Enter User PIN by typing in user 2 digit personal identification number and press **Enter**.

The main display will now be present.

**Step 7:** Press the **Test** button on the keypad.

**Step 8:** Set location using the **arrow keys**, select the Test Location and press **Enter**. Proceed to Step 9.

*If the correct location is not present select **New Item** and press **Enter**.*

### NEW LOCATION

Type in the new location and press **Enter**.

### NEW ADDRESS

Type in the address of the new location and press **Enter**.

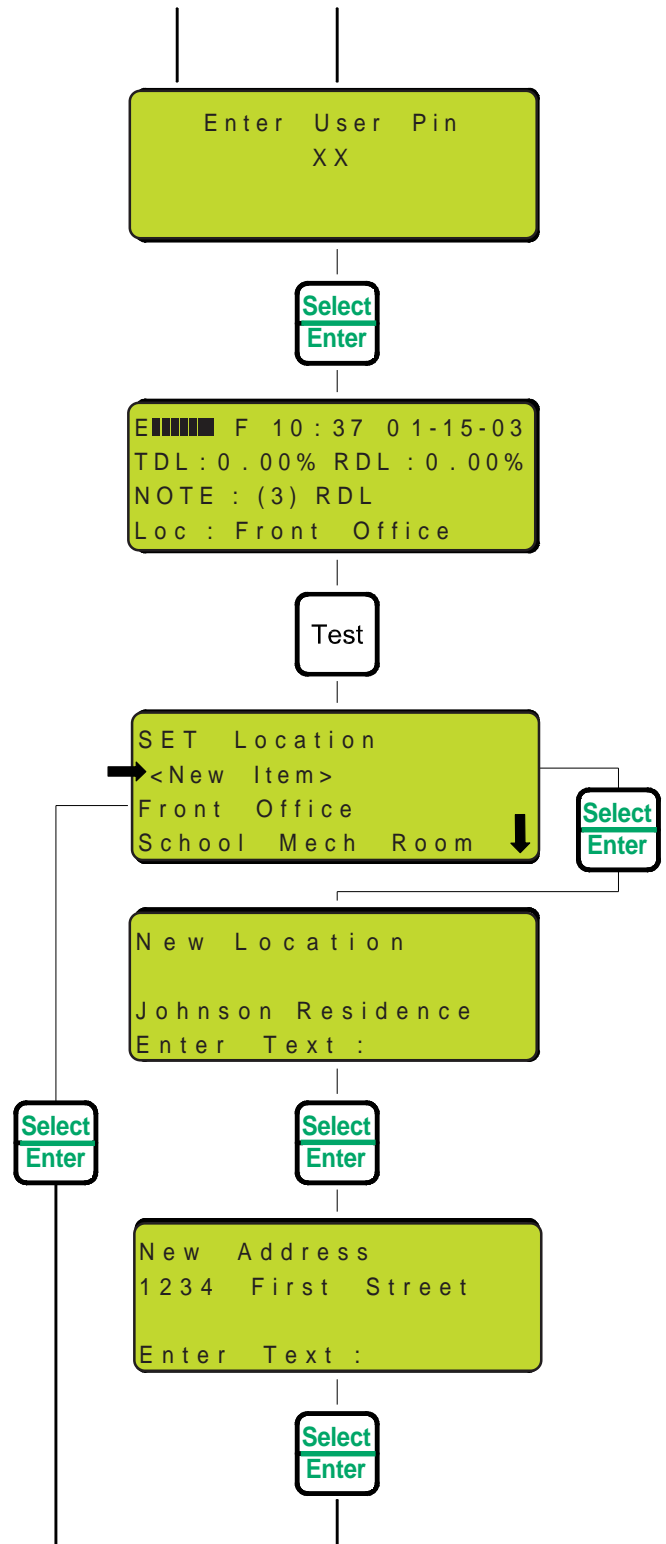

# SECTION 6: PROGRAMMING FOR ODOR INTENSITY OPERATION

## Conducting An Odor Intensity Test: (cont.)

Set City using the **arrow keys**, select the city and press **Enter**.

*If the correct city is not listed, select **New Item** and press **Enter**.*

New City: type in the name of the **New City** and press **Enter**.

Set State/Province using the **arrow keys**, select the state and press **Enter**.

*If the correct State/Province is not listed select **New Item** and press **Enter**.*

New State: type in the name of the new State/Province and press **Enter**.

Set Zip/Postal Code using the **arrow keys**, select the correct zip code and press **Enter**.

*If the correct Zip Code is not listed select **New Item** and press **Enter**.*

New Zip/Postal Code: type in the new zip/postal code and press **Enter**.

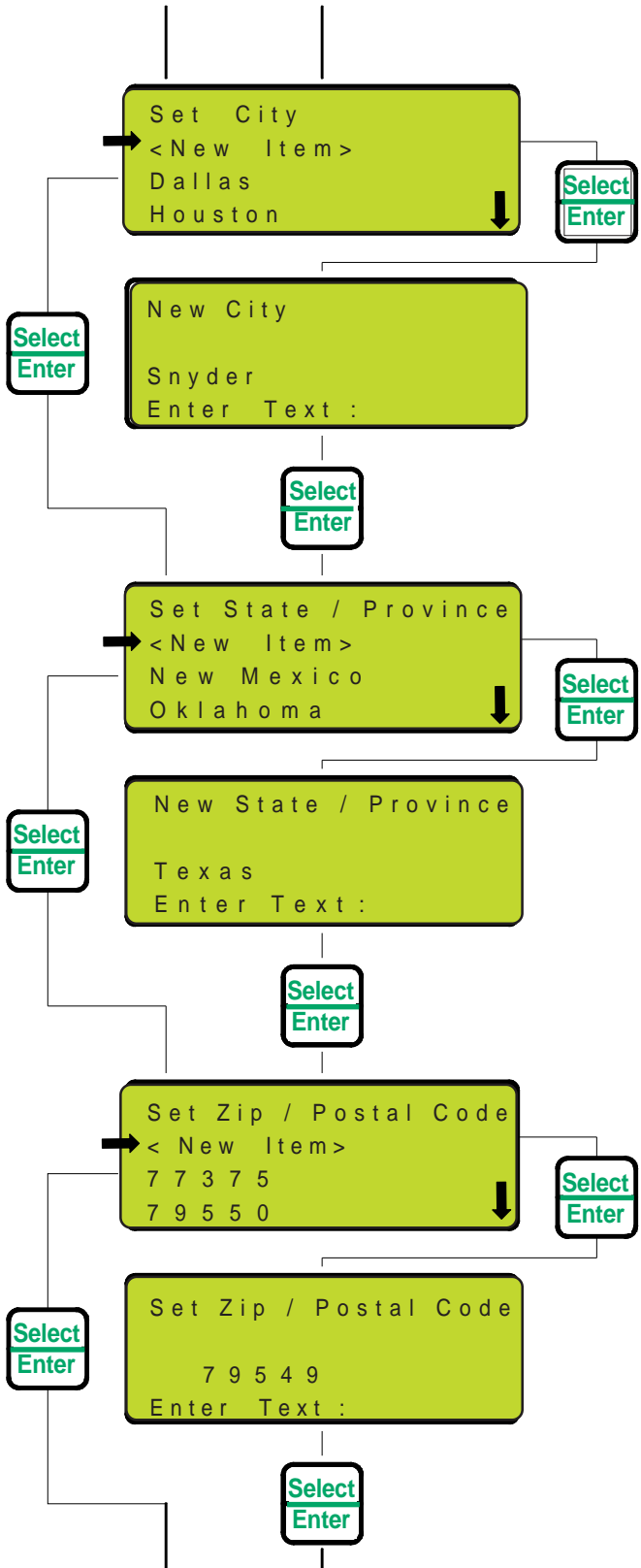



# SECTION 6: PROGRAMMING FOR ODOR INTENSITY OPERATION

## Conducting An Odor Intensity Test: (cont.)

**Step 9:** Set the altitude using the **arrow keys** and press **Enter**. (Set to nearest 500 feet.)

**Step 10:** Verify Data: verify that all data entered for test location is correct by using arrow keys to scroll through data. Press **Enter** to continue.

**Step 11:** Is Data Correct? If correct, select **Yes** and press **Enter** and proceed to Step 12. If data is incorrect select **No** and press **Enter**. Re-enter information as required.

*The configuring hardware display will be present and the unit will begin to run to configure hardware for a test.*

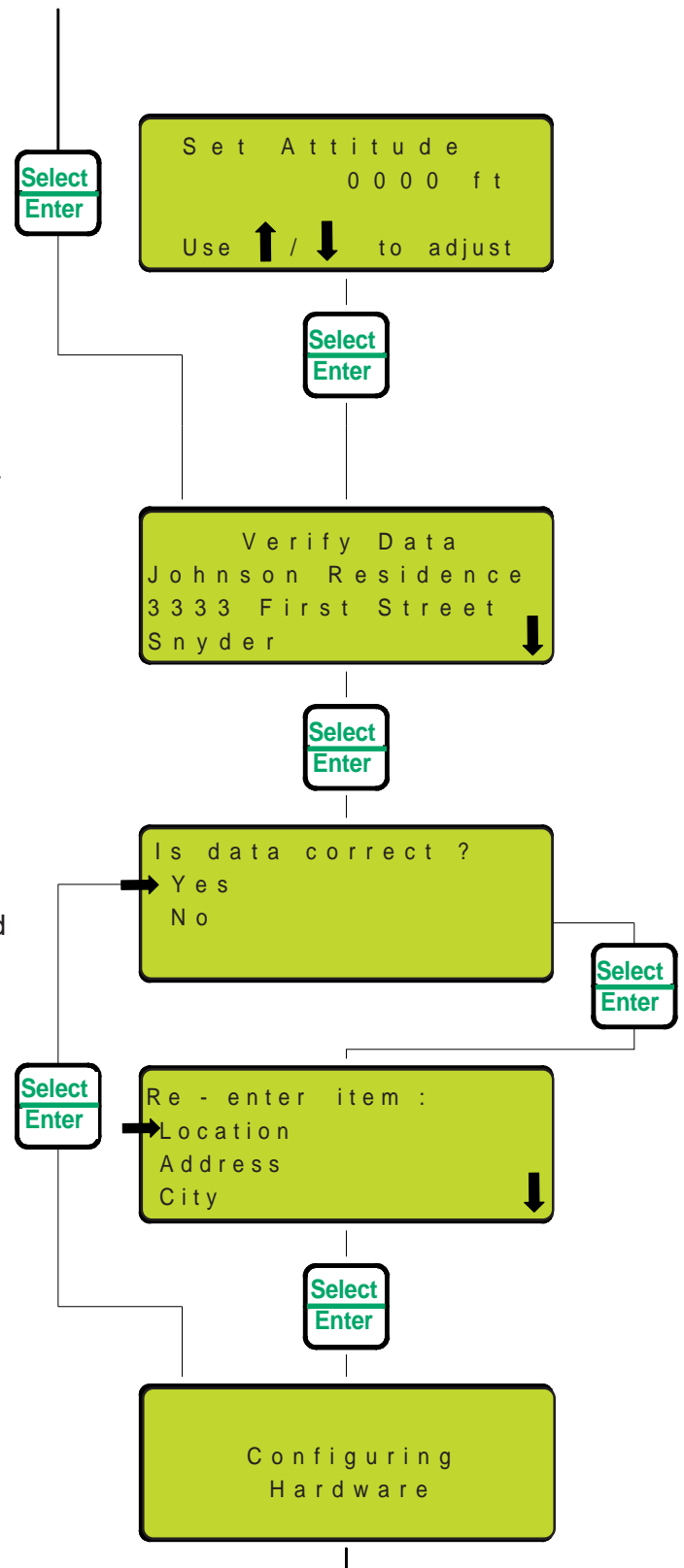

## SECTION 6: PROGRAMMING FOR ODOR INTENSITY OPERATION

### Conducting An Odor Intensity Test: (cont.)

**Step 12: Threshold Detection Level (TDL) Test:** position nose within 3/4 inch of the sniff chamber and with valve closed sniff exhaust. If an uncharacteristic odor is detected allow the instrument to operate for an additional 2 minutes. If uncharacteristic odor persists, perform an exhaust background evaluation test as specified in Section 7 - System Maintenance. Slowly open the flow valve and sniff exhaust. Continue to open the valve and sniff, getting breaths of fresh air between sniffs. Continue the procedure until the first hint of a new odor is detected. This is the **threshold detection level**. Threshold, as used here, is the minimum Intensity of a gas in air when one detects a new or different odor (above the background/characteristic odor of instrument). Remove nose from sniff chamber.

**Step 13:** Press the **Record Test Level (RTL)** key recording the **threshold detection level\***.

**Step 14:** Press the **Test** key to toggle your DTEX instrument into the Odor Intensity test mode. Quickly open the flow valve until the RDL Flow value in the display equals the gas concentration in air % desired for this test.

**Step 15:** Position nose within 3/4 inch of the sniff chamber. Make a mental note of a rating for the intensity of the odor in the air/gas mixture, for use in step 18.

*\*Typical ratings are (1) absent, (2) barely detectable, (3) RDL readily detectable, (4) strong, or (5) very strong or obnoxious.*

**Step 16:** Press the **Record Test Level (RTL)** key.

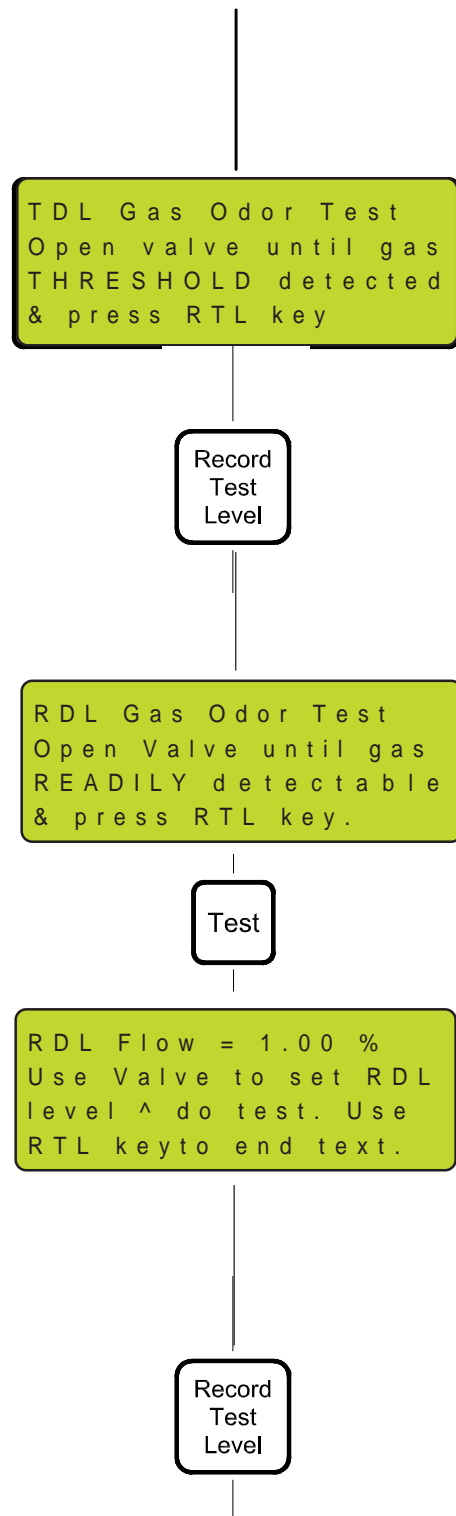

## SECTION 6: PROGRAMMING FOR ODOR INTENSITY OPERATION

### Conducting An Odor Intensity Test: (cont.)

**Step 17:** Test Complete: Close valve and press Enter.

**Step 18:** Enter Intensity Rating Notes:  
\*Typical ratings are (1) absent, (2) barely detectable, (3) RDL readily detectable, (4) strong, or (5) very strong or obnoxious press **Enter**.

The main display will be present and test results are revealed to the operator.

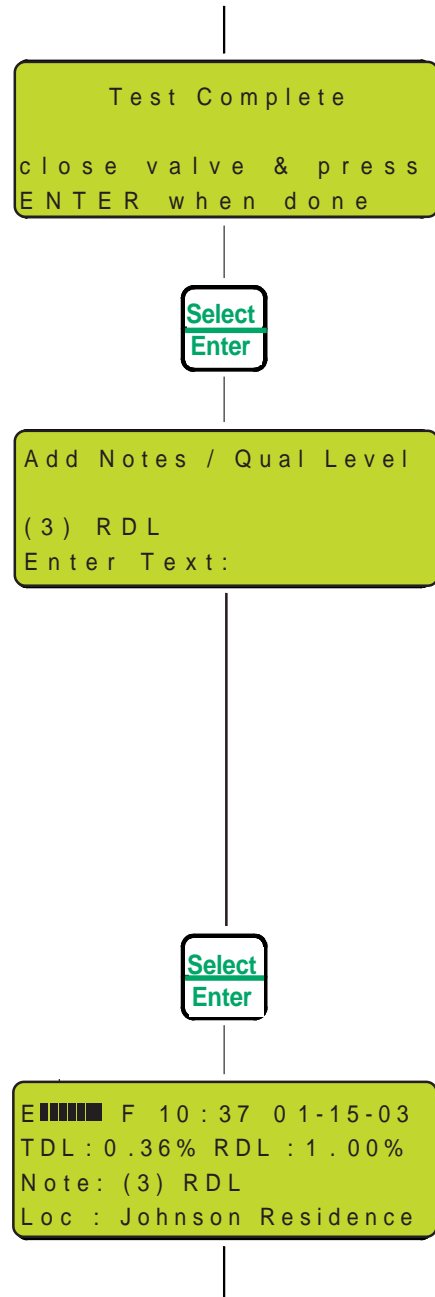

*\*refer ASTM D6273-98 definitions*

# SECTION 6: PROGRAMMING FOR ODOR INTENSITY OPERATION

## Conducting An Odor Intensity Test: (cont.)

**Step 18:** press the **PWR** key.

The following will be displayed:

Press: **PWR** to shut down  
**V** to vent unit  
**ESC** to abort

When finished with a test, the operator has the option to:

**PWR TO SHUT DOWN:** power down the system without venting.

To be used after data review or data entry when no gas source connection has been made.

**V TO VENT UNIT:** vent the system before shut down.

Recommended after each test to prevent undue saturation of inlet hose, system components and residual smell in the unit.

To vent:

1. Close the source isolation valve.
2. Remove the gas inlet hose from the source connection.
3. Press **V** to vent.
4. Open the flow valve fully.
5. Wait until prompted on screen.
6. Close flow valve.
7. Press **PWR** to shut down.

**ESC TO ABORT:** to review or re-run the previous test.

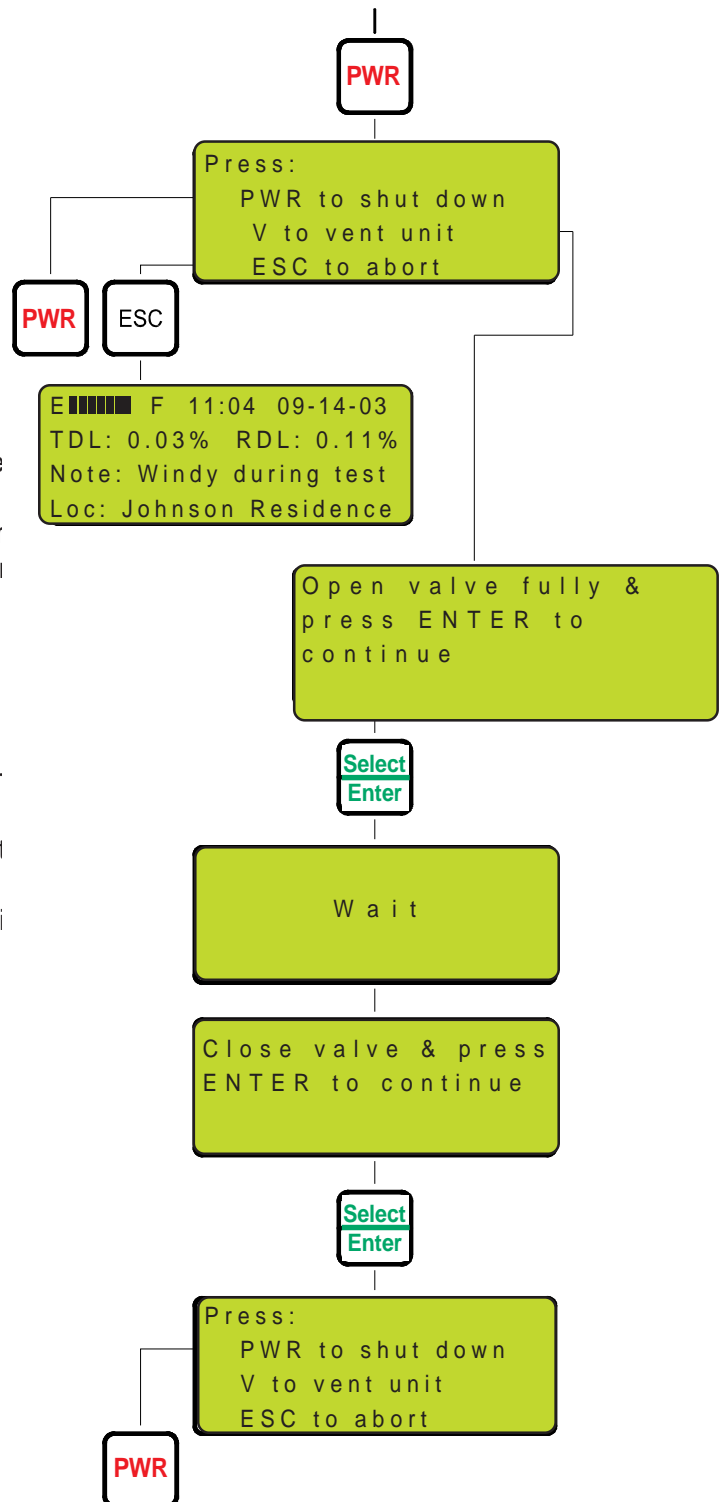

# SECTION 7: SYSTEM MAINTENANCE

## Maintenance

The DTEX system essentially requires no in the field maintenance. There are **NO** field service-able components. **ALL** service and re-calibration must be performed by the factory.

Please note the following items to insure trouble free service:

**1. The unit requires annual re-calibration.**

The scheduled re-calibration date is displayed at power up and is also available by pressing the **Info** key at the main display screen. Refer to Section 12 for re-calibration information.

**2. Recharge of the system battery** will be required periodically. Battery condition is shown at the main display screen.

**3. Do not expose the unit to debris - Damage Will Result!** Keep lid closed and gas inlet capped when not in use. Keep air intake and sniff chamber clean.

**4. Clean the unit with a damp cloth.** Avoid cleaners which could damage the display/keypad and possibly leave a residual odor.

**5. Properly vent the unit after testing.** Failure to vent gas from the unit after testing may lead to odor saturation of internal components.

**6. Each instrument has its own unique background smell, just as each room has a smell peculiar to it.** Every 30 days perform an exhaust background evaluation. Without connecting gas to the inlet, power on the unit, open the flow valve fully and press **P** on the keypad to purge the unit. Purge for 2 minutes before closing valve and pressing **Enter** key to conclude the purge procedure. If after 2 minutes, smell persists over and above normal background send unit to be serviced.

## Recommended Spare Parts List:

Part #	Description	Quantity
G2-0053	RS-232 Cable (12 ft.)	1
G2-0050	Power adapter assembly	1

# **SECTION 7: SYSTEM MAINTENANCE**

## **Annual Calibration/Inspection**

For system integrity and accuracy, an annual re-calibration and inspection of the DTEX system is required. The unit displays the next scheduled calibration date at start up and also in the information section, accessed via the keypad. The system will continue to operate if past due calibration, however all tests conducted with the unit in this state will be identified as such.

When the unit is due for calibration, please photocopy the accompanying information page, fill in, and call:

YZ Systems - DTEX Customer Service Division.  
For a return authorization number.

**1-800-653-9435 or 936-788-5593**

Return the completed information sheet with the unit to:

**YZ Systems**  
**206 Old Lubbock Hwy**  
**Snyder, Texas 79549**

Be sure to display return authorization number on exterior of shipping container.

Always package the unit for safe shipment.



# **SECTION 7: SYSTEM MAINTENANCE**







3101 Pollok Drive

Conroe, Texas 77303

800.653.9435

P: 936.788.5593

F: 936.788.5698

Em: [Service@yzhq.com](mailto:Service@yzhq.com)

Web: [www.yzsystems.com](http://www.yzsystems.com)

*YZ Systems, Inc. represents and warrants that for a period of 1 year from receipt of the product: (1) the product will be free from defects in materials and workmanship; and (2) the product will perform substantially in accordance with product manuals, literature, or documentation. Any written or oral information or advice given by YZ representatives, agents, or employees will in no way increase the scope of this warranty. If the product fails to comply with the warranty set forth herein, YZ's entire liability and the customer's exclusive remedy will be replacement of the product(s) or, at YZ's option, YZ's reasonable effort to make the product meet the warranty set forth herein. **YZ disclaims all other warranties, either expressed or implied, including but not limited to, implied warranties or merchantability and fitness for a particular purpose, with respect to the product.** This limited warranty gives you specific legal rights. You may have others, which vary from state to state. **These remedies are not available outside of the United States and Canada.** In no event shall YZ or its suppliers be liable for any damages whatsoever (including, without limitation, damages for loss of profits, business interruption, loss of information, or other pecuniary loss) arising out of the use of or inability to use the product, even if YZ has been advised of the possibility of such damages. Information contained in this document is subject to change without notice and does not represent a commitment on the part of YZ Systems, Inc. All prices quoted are in U.S. dollars, F.O.B. Snyder, Texas. LINC, LINC Chemical Pumps, and LINC Level & Flow Switches are trademarks of YZ Systems, Inc. All other product names and/or registered trademarks are the property of their respective holders. YZ support services are subject to YZ's then-current prices, terms, and conditions, which are subject to change without notice. All prices and specifications, if published, are subject to change without notice.*